

Operating and installation instructions

R-IMC-BUS
Filter control system

RM-351 C / 310

CompactLine

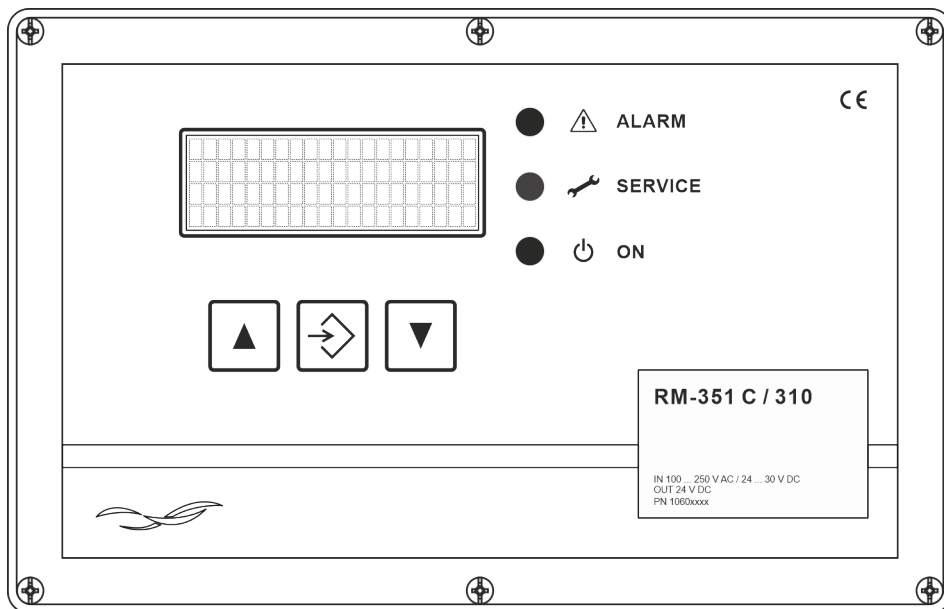

Contents

1	Safety instructions	3
2	Device description	3
3	Mechanical installation.....	4
4	Electrical installation	5
5	Settings.....	10
5.1	Function in "as delivered" condition	10
5.2	Jumper on the RM-351 C / 310 board	11
5.3	Operating and display elements	12
5.4	Parameter selection level.....	13
5.5	Parameter setting level	14
5.6	Code input to release locked parameters	14
5.7	Return to the operating level	14
5.8	Short instructions for parameter setting.....	15
5.9	Overview of menu navigation.....	16
5.10	Parameter list.....	20
5.11	Fast display of the most important current operating and parameter values.....	22
5.12	Parameter description and explanation of function.....	24
6	Operating modes	29
6.1	Continuous cleaning (Parameter FAS 25)	29
6.2	Forced cleaning (Parameter FAS 18)	29
6.3	Differential pressure controlled cleaning (Parameters FDP1 15, FDP1 16, FAS 25)	29
6.4	Downtimecleaning.....	30
6.5	Cleaning request and release via a control room	30
6.6	Activation of cleaning via an external input signal.....	30
6.7	Manual operation	30
7	Functions for commissioning and service purposes.....	32
8	Text messages on the display	33
8.1	Program start	33
8.2	I/O module initialisation.....	33
8.3	Meaning of the signs in the differential pressure display	34
8.4	Operating messages.....	35
8.5	Service and alarm messages	41
8.6	Acknowledgement of service and alarm messages	42
9	Overview of all available functions.....	43
10	Technical specifications.....	44

Regulations

2014/30/EU

2014/35/EU

Symbol explanation



Warning of physical and health hazards or damages to the product and other properties.



Important note

1 Safety instructions

The RM-351 C / 310 filter control carries hazardous electrical voltage when connected to the mains. Improper installation of the connected electrical equipment may cause device failure, serious or even fatal injuries. In addition to general safety rules for equipment in industrial electrical installations, pay particular attention to the following points:

- The equipment must only be installed by qualified persons according to the provisions of the standards IEC 364 and DIN VDE 0105 for electrical equipment.
- All applicable laws, conditions, rules and regulations governing the installation of electrical equipment must be observed.
- Equipment with protection rating IP00 without covers must only be configured by authorised expert staff when disconnected and whilst observing the local safety and accident prevention rules.

The RM-351 C / 310 is only allowed to be operated in its specified operating range.



Switch off the supply voltage before replacing the filter control or components connected to it. Failure to do so may cause equipment damage.

2 Device description

The RM-351 C / 310 controller is the master control of a modular filter control system for filtering separators with compressed air pulse cleaning. The intelligent I/O modules RM-V 8 and RM-V 16 handle distributed measuring and control tasks.

The R-IMC-Bus (RECO – Inter Module Communication) employed for data transfer between the individual control components was developed specifically for use in industrial environments. Data exchange with the external components may optionally also be performed via Profibus, Profinet or Modbus.

Once the supply voltage and the intelligent I/O modules have been connected the RM-351 C / 310 filter control works fully automated without further handling.

3 Mechanical installation

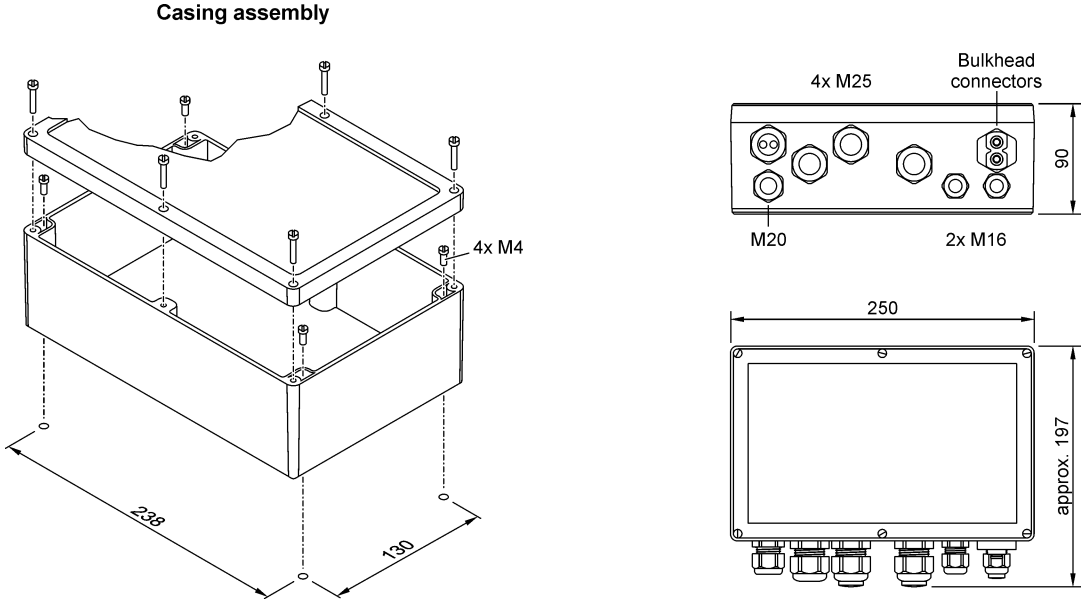

4 Electrical installation

Overview of the terminals and plug-in-module slot A

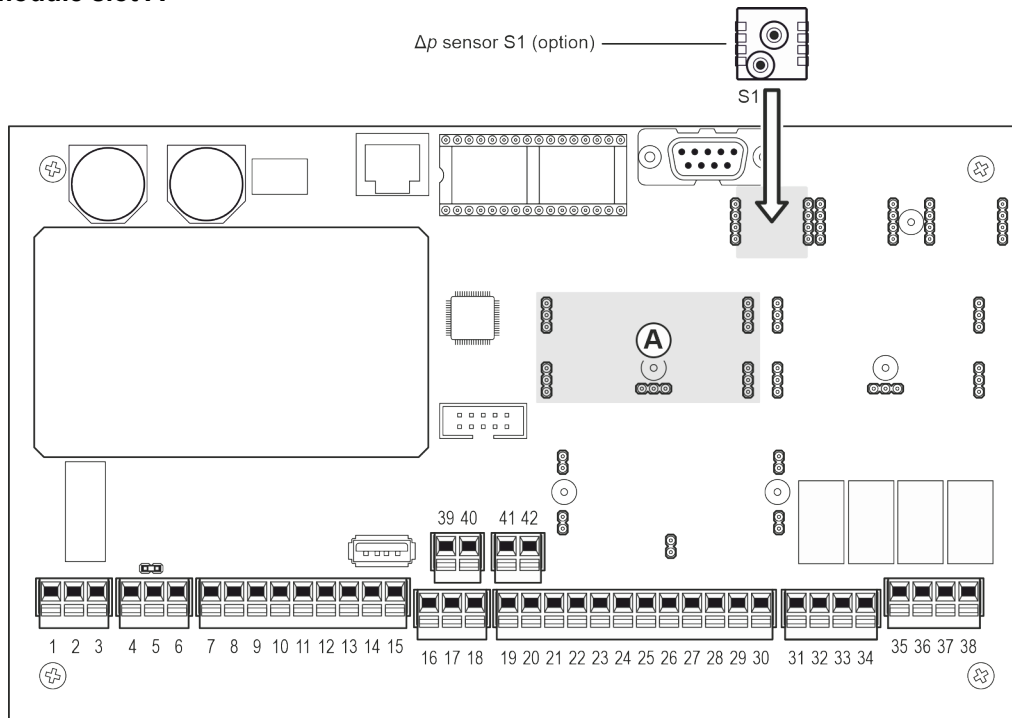

Optional plug-in module to extend the range of functions (slots A)

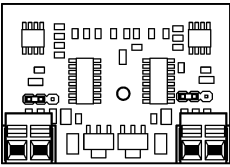
Slot	Module
(A)	 <p>4-20 mA module The module provides 1 analog outputs 4-20 mA.</p>

Terminal diagrams

1 Supply voltage



2 R-IMC Bus – Connection of the RM-V8 / RM-V16 I/O modules

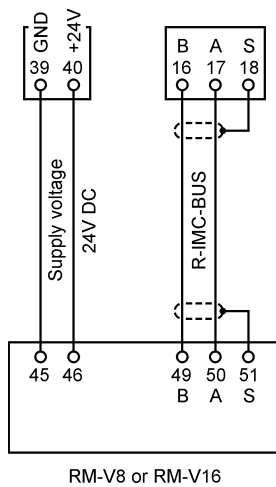

i

Use a shielded bus cable for the R-IMC bus. Connect one end of the shielding to terminal 18 of the filter control RM-351 C / 310 and the other end to terminal 51 of the I/O module RM-V8 or RM-V16.

3 Relay outputs A1 ... A4, potential-free

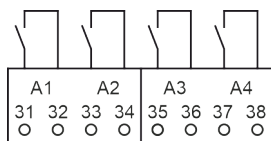

Output	Factory-set function
A1=0	The relay contact closes as soon as the supply voltage is applied to RM-351 C / 310. It opens any time an alarm is present (Group Alarm).
A2=1	Contact closes at active cleaning and at downtime
A3=1	Contact closes at Δp min. alarm
A4=1	Contact closes at Δp max. alarm

i

The function of the outputs can be changed via the digital output assignment. See Appendix 1 "Parameterizable output assignment".

4 Digital inputs E1 ... E6

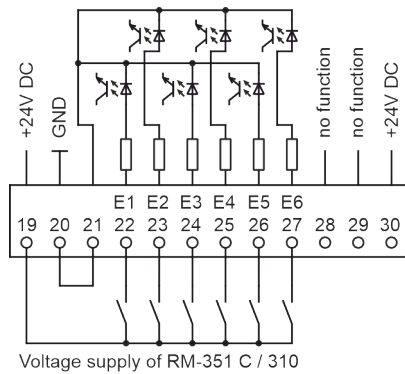

Voltage supply of RM-351 C / 310

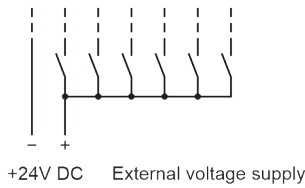

Input	Factory-set function
E1=1	Release of the control when a 1 signal is present
E2=1	Function selectable (see appendix 2)
E3=1	Acknowledge alarm
E4=1	Continuous cleaning with pause time 1
E5=1	Cleaning off (priority over Cleaning on)
E6=1	Cleaning release

i The function of the inputs can be changed via the digital input assignment. See appendix 2 "Parametrizable input assignment".

5 4-20mA inputs I2, I3 und I4 „Differential pressure“

2-wire connection

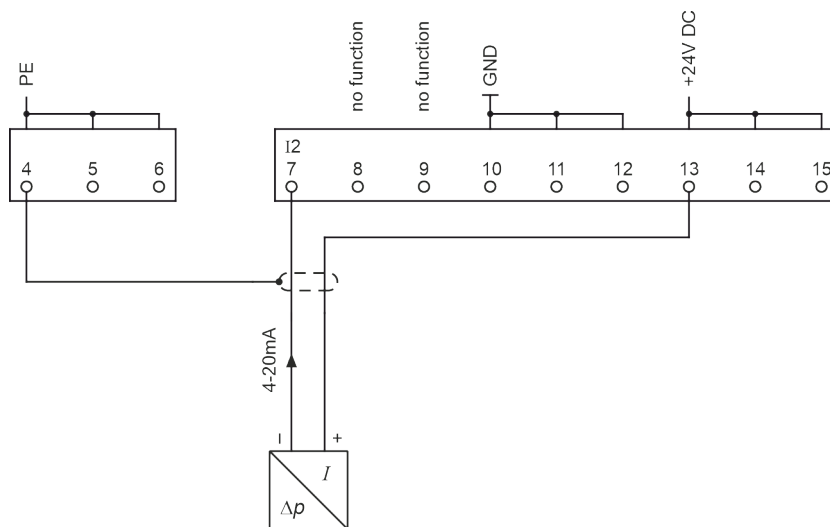

4-wire connection

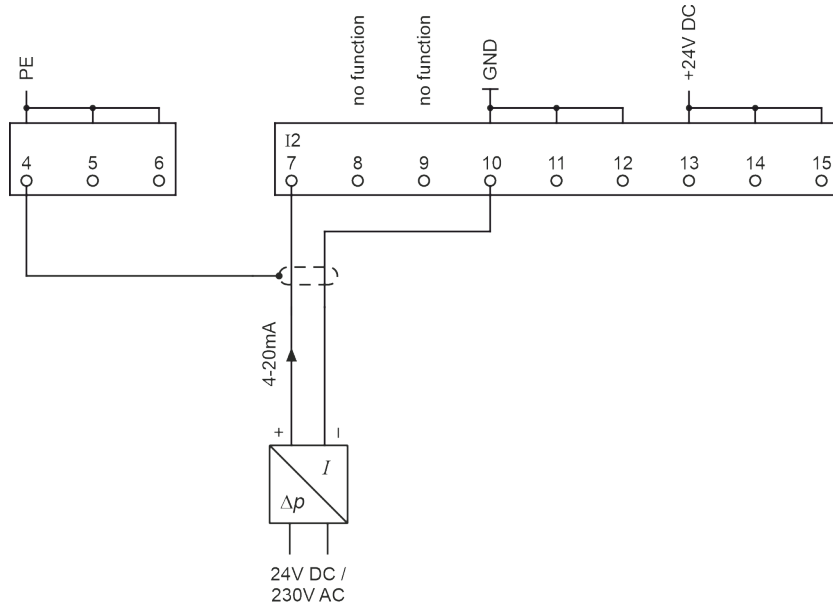

i Generally use shielded cables for 4-20mA signals and connect the shield to a PE terminal.

6

Optional analogue output 4-20 mA

For this function the 4-20 mA module must be plugged into slot A.

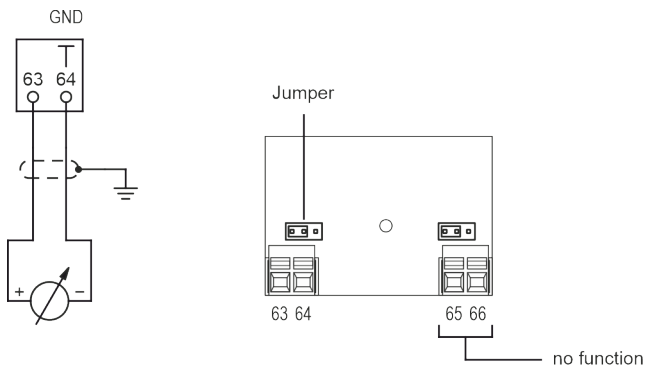

7

Differential pressure measuring lines

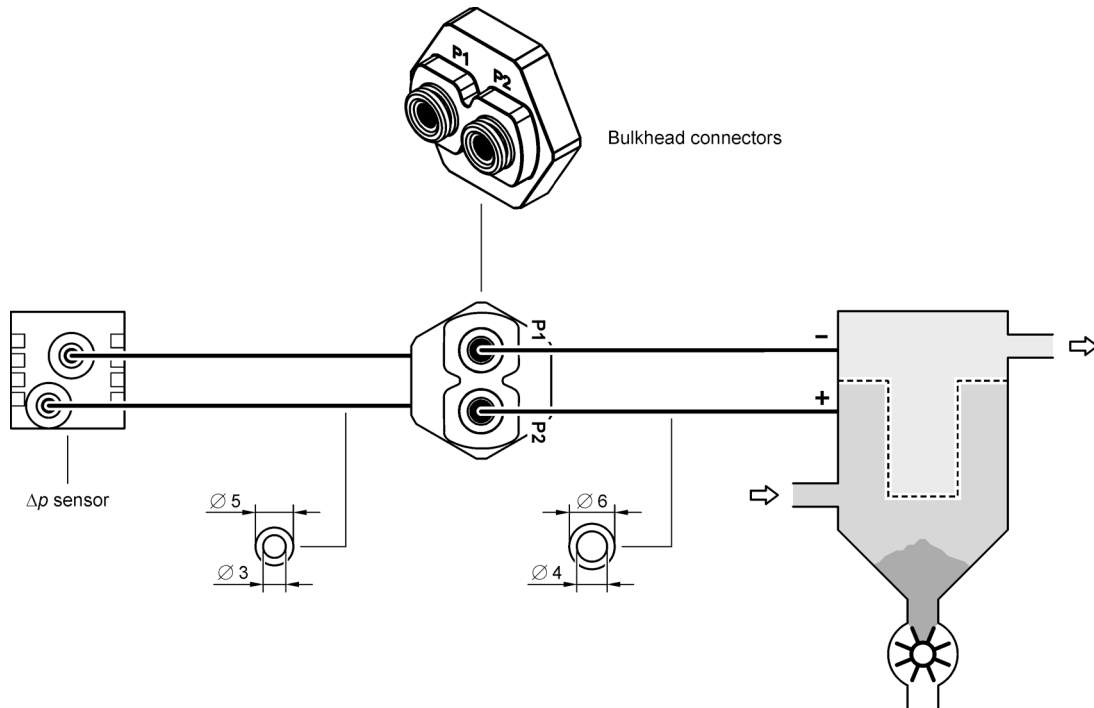

Slot for the
 Δp sensor S1 (option)

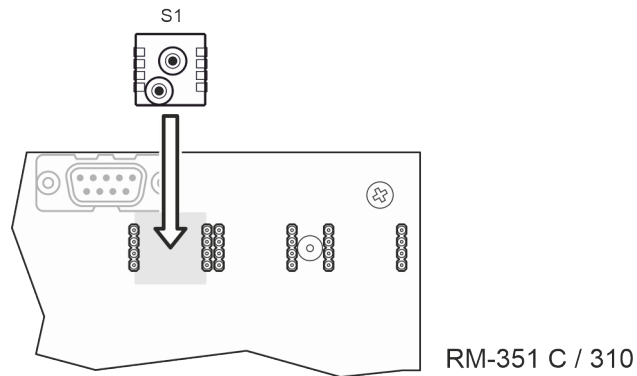

RM-351 C / 310

General information about the installation of the filter control

i

- Use shielded cables for all bus connections.
- Signal cables are not allowed to be installed parallel to power cables.
- All cable glands must be firmly tightened to make sure all cables are solidly enclosed and no water can enter.
- Unused cable glands must be closed and replaced with blind plugs.

5 Settings

5.1 Function in "as delivered" condition

The input and output functions of the controller are preset. The following parameters must be adjusted before operating the RM-351 C / 310:

FAS 20 Number of valves

FAS 21 Number of connected I/O modules RM-V 8 / RM-V 16 (if available)

The RM-351 C / 310 works fully automatic after the number of the I/O modules and valves have been set.

Cleaning starts when the filter's differential pressure Δp has reached the DP Start value (factory setting: 1000 Pa). The solenoid valves are controlled sequentially. By cleaning the differential pressure drops after a certain period of time. Once the differential pressure has reached the value DP Start minus DP Hysteresis (factory setting: 300 Pa), i.e. the differential pressure is 1000 Pa - 300 Pa = 700 Pa, cleaning stops.

If a different function is desired or additional functions shall be activated, the parameter setting of the RM-351 C / 310 must be changed.

Preset functions of the outputs

Output	Terminals	Function
A1	31, 32	The relay contact closes as soon as the supply voltage is applied to RM-351 C / 310. It opens any time an alarm is present (Group Alarm).
A2	33, 34	Contact closes at active cleaning and at downtime
A3	35, 36	Contact closes at Δp min. alarm
A4	37, 38	Contact closes at Δp max. alarm

Preset functions of the inputs

Input	Terminals	Function
E1=1	22	Release of the control when a 1 signal is present
E2=1	23	Function selectable (see appendix 2)
E3=1	24	Acknowledge alarm
E4=1	25	Continuous cleaning with pause time 1
E5=1	26	Cleaning off (priority over Cleaning on)
E6=1	27	Cleaning release

5.2 Jumper on the RM-351 C / 310 board

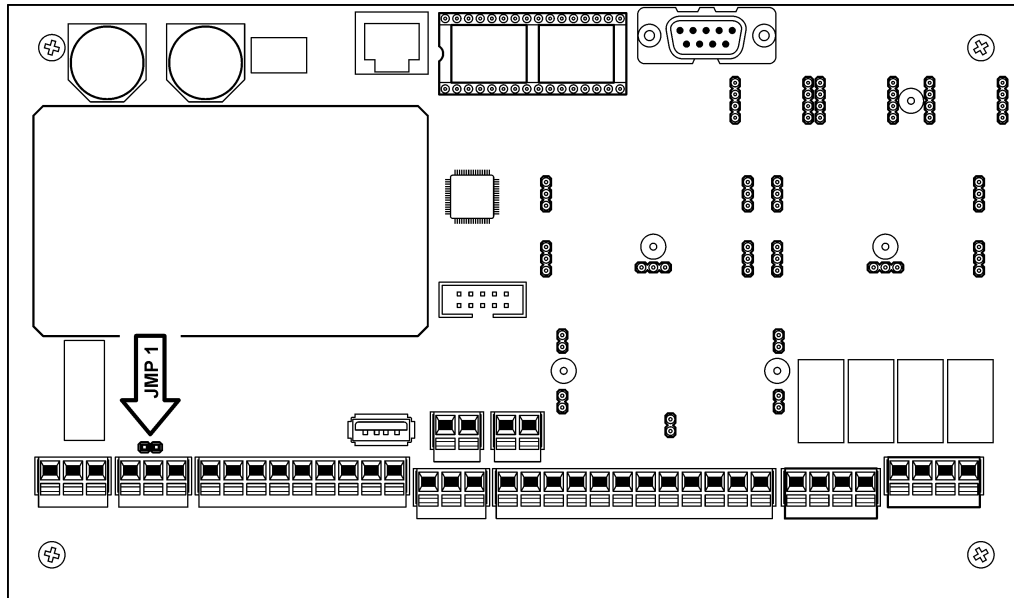

Jumper	Default setting	Function
JMP 1		To activate the terminating resistor of the RS-485 bus interface. (Jumper plugged in = termination resistor active)

5.3 Operating and display elements

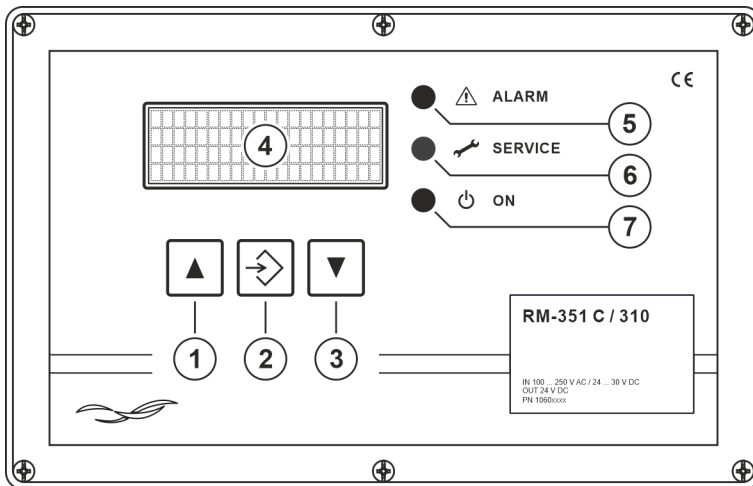

①	△ key	<ul style="list-style-type: none"> in parametrisation mode* to select parameters and values (in upward direction). in operating mode to call up the individual function data and text messages (in upward direction)
	F1 key	to execute the action shown on the display under TF1
②	ENTER key	<ul style="list-style-type: none"> in parametrisation mode* to change to the parameter setting level and to save changed parameter values. If a service or alarm message is present, to acknowledge the message
	F2 key	to execute the action shown on the display under TF2
③	▽ key	<ul style="list-style-type: none"> in the parametrisation mode* to select parameters and values (in downward direction). in operating mode to call up the individual function data and text messages (in downward direction)
	F3 key	to execute the action shown on the display under TF3
④	Display	To display text messages (4 x 20 characters)
⑤	"ALARM" LED	lights when an alarm message is present
⑥	"SERVICE" LED	lights when a service message is present
⑦	"ON" LED	<p>Lights when the device is in operation</p> <p>Does not light when the device is on the parameter selection level.</p> <p>Flashes when the device is on the parameter setting level.</p>

* The RM-351 C / 310 is on the parameter selection or parameter setting level.

5.4 Parameter selection level

To view the parameters and their values the user must switch from the operating level to the parameter selection level. The Δ and ∇ keys are pressed simultaneously until the green "ON" LED goes off (approx. 3 seconds).

All parameters can now be viewed in sequence by repeatedly pressing the Δ or ∇ key. For parameters that are switched off (not active), the text "Not active" is displayed instead of the value. This also applies to parameter blocks. For parameters that are hidden, the text "hidden" is displayed instead of the value.

Parameter blocks

To ensure an uncluttered view of the device's parametrisation, parameters referring to the same function are grouped into blocks (FAS, FDP, etc.). For example, the block FAS "Filter cleaning" contains all parameters (FAS 10 to FAS 31) that relate to the control of the filter cleaning.

A deactivated block is inactive. All parameters assigned to it are without function and are not shown.

i To activate a disabled parameter group switching to the parameter setting level is required (see section 5.5 "Parameter setting level" on page 14).

Parameter display examples

Parameter block FAS, activated

Display	Explanation
<pre>FAS Filter cleaning active 1 Admin-Pass. 3</pre>	<p>Parameter block FAS "Filter cleaning"</p> <p>The block is active (activated)</p> <p>The selected option "active" has the sequence number 1. The block is protected by parameter code 3.</p>

Parameter block FAS, deactivated

Display	Explanation
<pre>FAS Filter cleaning Not active 0 Admin-Pass. 3</pre>	<p>Parameter block FAS "Filter cleaning"</p> <p>The block is inactive (deactivated)</p> <p>The selected option "not active" has the sequence number 0. The block is protected by parameter code 3.</p>

Parameter 11 of parameter block FAS

Display	Explanation
<pre>FAS Filter cleaning 11 Pause time 1 1,0s</pre>	<p>Parameter block FAS "Filter cleaning"</p> <p>Parameter 11 "Pause time 1"</p> <p>Set value of parameter 11</p>

5.5 Parameter setting level

To change the value of a selected parameter or to activate and deactivate a parameter block the user must switch from the parameter selection level to the parameter setting level. To do this, press the ENTER key until the green LED "ON" starts to flash.

i For parameters blocked by a code, the entry of a 4-digit code is required to release the parameter (refer to section 5.6 "Code input to release locked parameters").

Subsequently, the parameter value can be changed or the parameter block activated or deactivated by pressing the Δ or ∇ key.

To save the set value or the status of the parameter block (active / not active or faded in / faded out) and to return to the parameter selection level, press the ENTER key until the green LED "ON" goes out and the display briefly shows `!!!!!! OK !!!!!!`.

If the set value or state should be discarded, the ENTER key simply needs to be briefly pressed. The character string "-----" appears briefly in the display and the controller switches to the parameter selection level without saving the changed value or status.

5.6 Code input to release locked parameters

There are 3 different codes that are used to allow access to certain parameters by authorised persons only. In the parameter selection mode, row 4 of the display shows what code has to be entered to release the displayed parameter (parameter code 3, 4 or 5). If nothing is displayed in the row 4, the relevant parameter can be accessed without code.

The 4-digit code must be entered as follows:

1. The code digit is selected by briefly pressing the ENTER key.
2. The digit value is set by briefly pressing the ∇ or Δ key.
3. The set code is confirmed by prolonged pressing of the ENTER key.

If the code entered is wrong the message `!Invalid Entry !` appears for 1 second. The code input must be repeated.

If the code entered is correct the message `!!!!!! OK !!!!!!` appears for 1 second

All parameters that were blocked by the same code are now released for setting. After leaving parametrisation, the entered codes remain active for 15 minutes. After this time the codes must be re-entered. When the supply voltage is switched off, all codes are deleted immediately.

5.7 Return to the operating level

To get to the operating level the ∇ and Δ keys must be pressed simultaneously until the green LED lights (approx. 3 seconds).

5.8 Short instructions for parameter setting

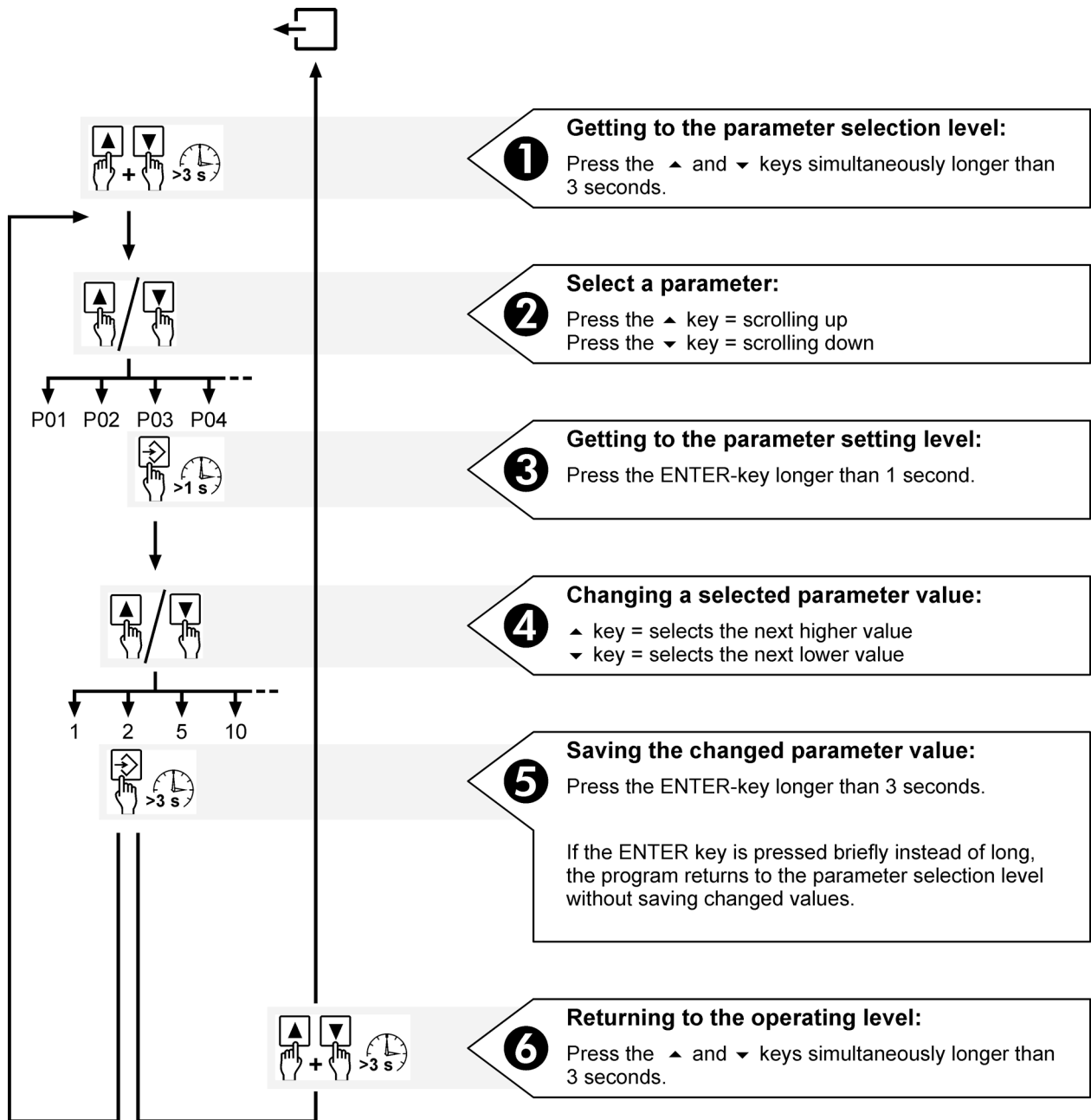

i The ON LED indicates the current level of the device.

LED **on** Operating level
LED **off** Parameter selection level
LED **flashing** Parameter setting level

If no key has been pressed for 3 minutes the RM-351 C / 310 automatically returns from the parameter selection or the parameter setting level with the last values stored to the operating level.

5.9 Overview of menu navigation

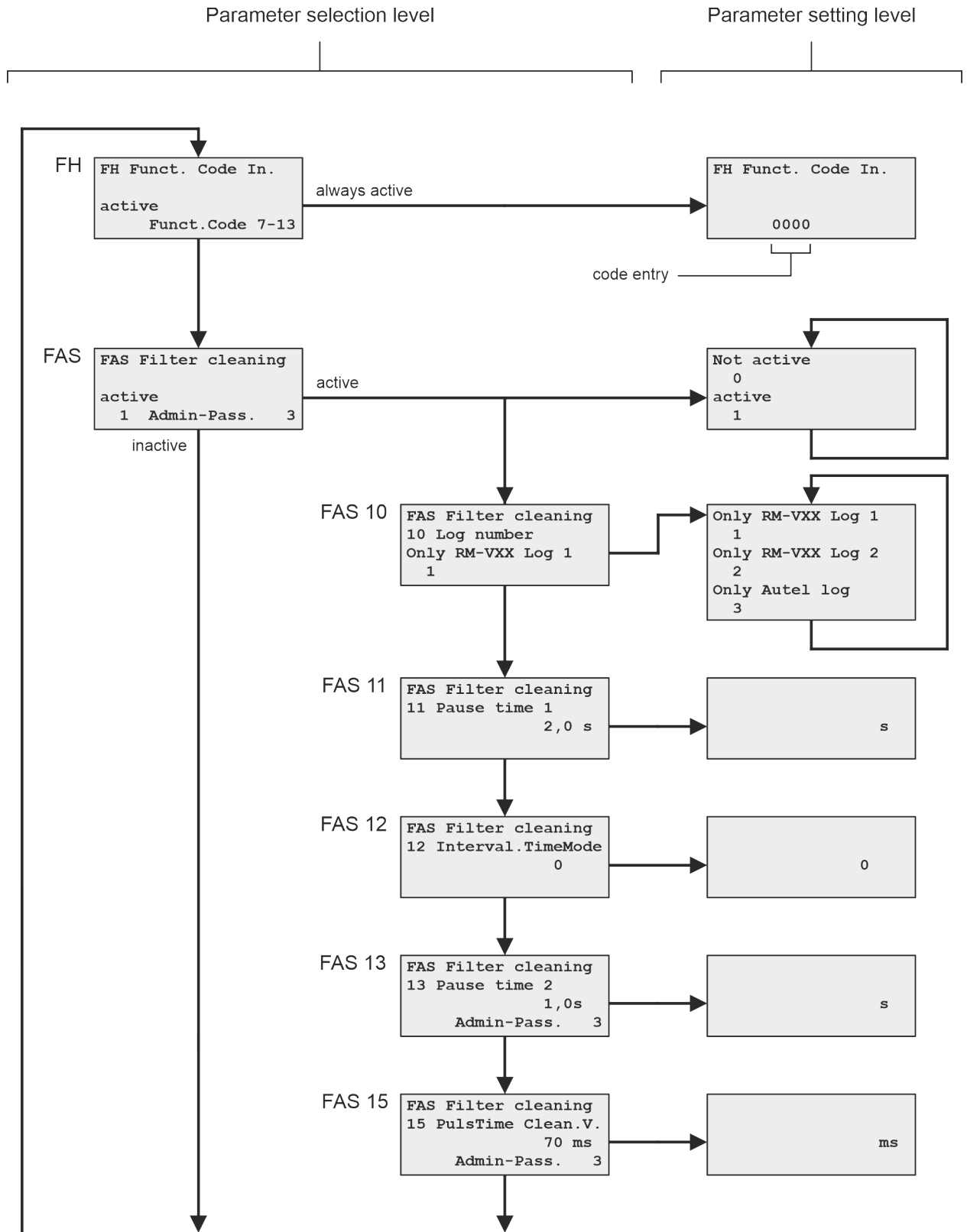

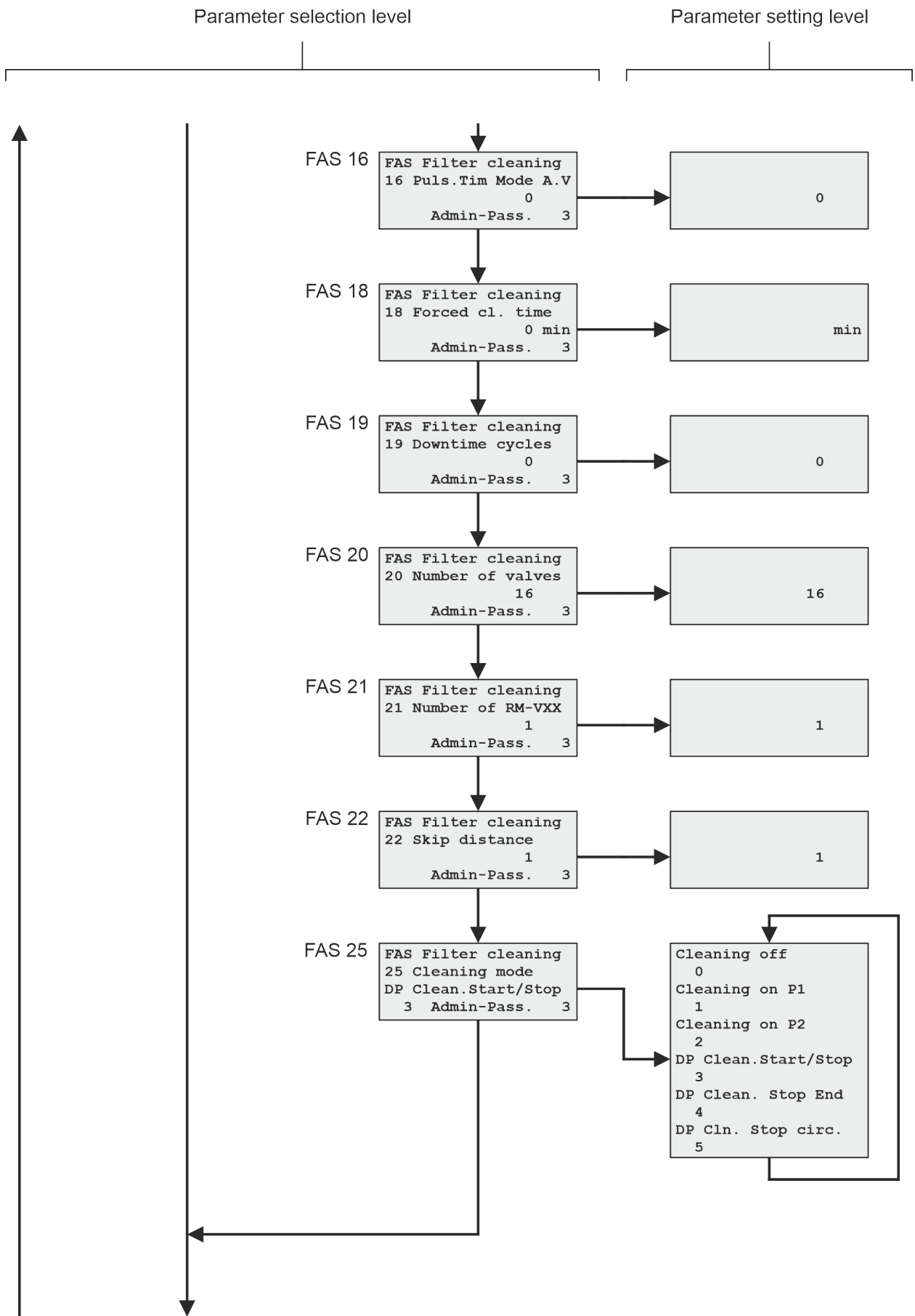

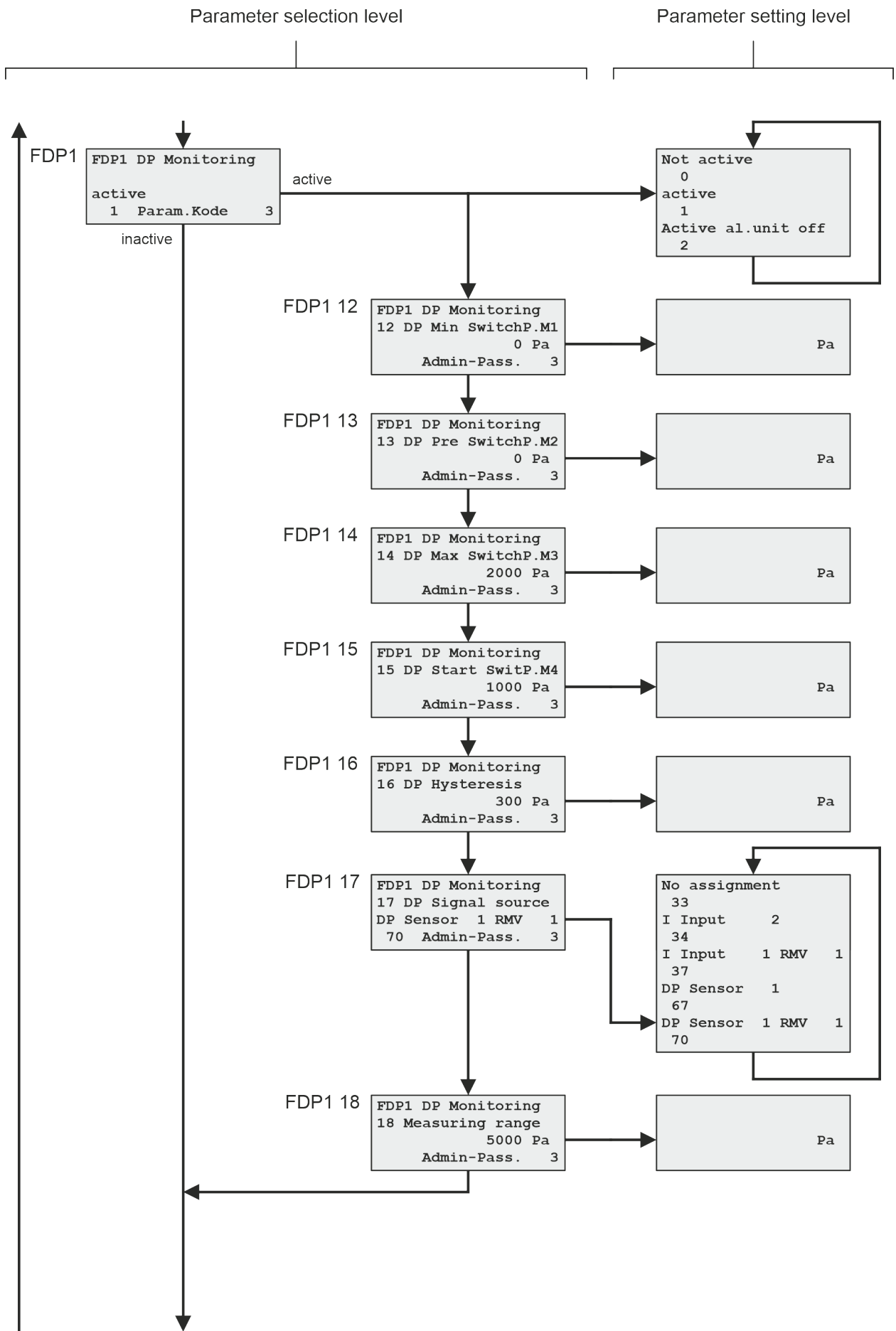

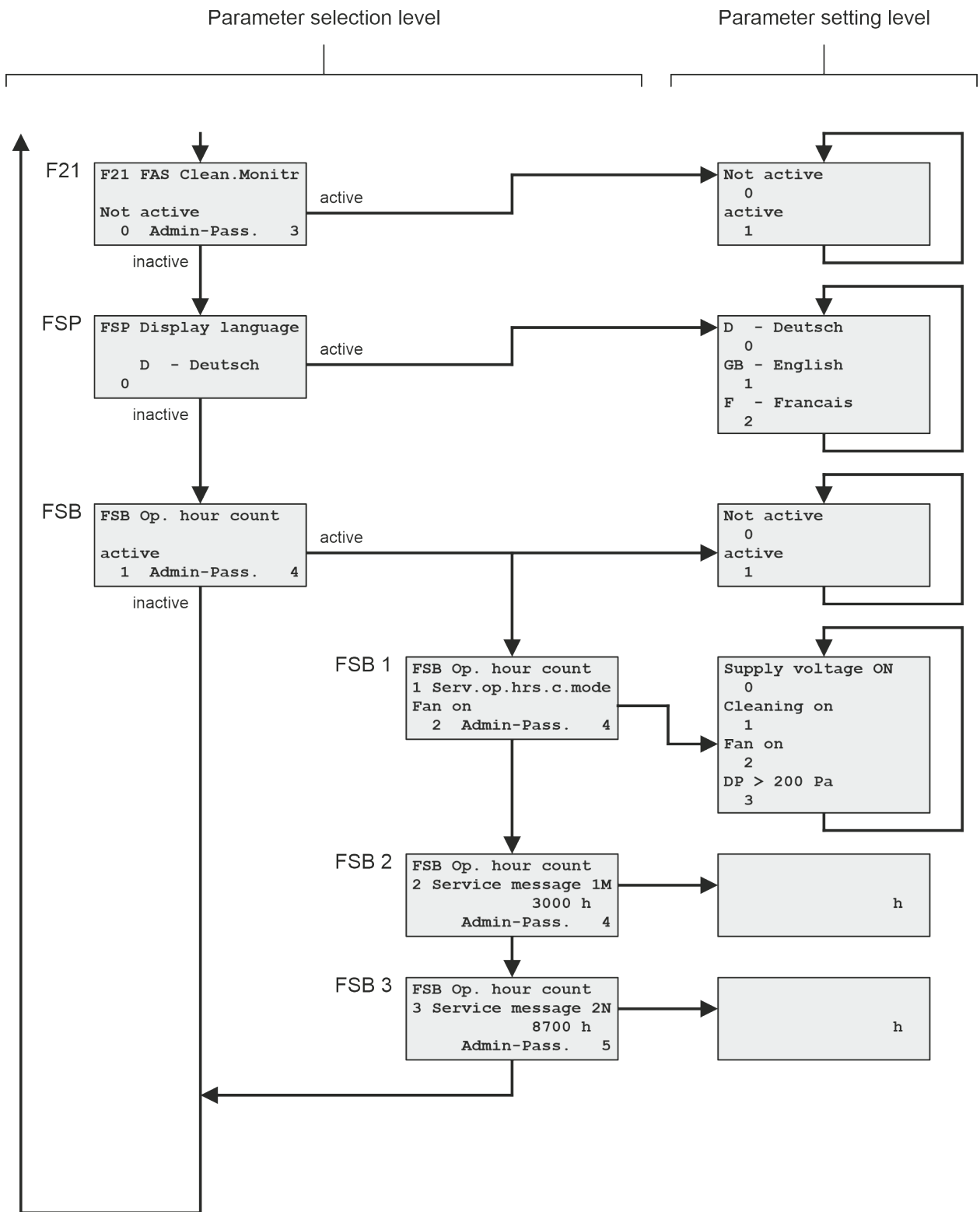

5.10 Parameter list

Parameter number	Code 	Display text	Explanation	Factory setting	Setting range	See page
Special functions						
FH	–	FH Funct. Code In.	Function code entry Special functions can be activated by entering function codes.	–	–	
Parameter block FAS "Filter cleaning"						
FAS	3	FAS Filter cleaning	Parameter block "Filter cleaning"	1	0, 1	24
FAS 10	3	10 Log number	Log number	1	1 ... 3	24
FAS 11	3	11 Pause time 1	Interval time 1	2 s	0.5 s ... 600 s	24
FAS 12	3	12 Interval.TimeMode	Pause time mode	0	0, 1	24
FAS 13	3	13 Pause time 2	Interval time 2	1 s	0.5 s ... 600 s	24
FAS 15	3	15 PulsTime Clean.V.	Pulse time for the cleaning valves	70 ms	50 ms ... 990 ms	24
FAS 16	3	16 Puls.Tim Mode A.V	Pulse time mode for cleaning valves	0	0, 1	24
FAS 18	3	18 Forced cl. time	Compulsory cleaning time	0 ¹	0 ¹ ... 2500 min	24
FAS 19	3	19 Downtime cycles	Downtime cycles	0 ¹	0 ¹ ... 64	24
▶ FAS 20	3	20 Number of valves	Total number of valves	16	0 ... 480	25
▶ FAS 21	3	21 Number of RM-VXX	Number of I/O modules RM-V 8 or RM-V 16	1	0 ... 30	25
FAS 22	3	22 Skip distance	Cleaning skip range	1	1 ... x ²	25
FAS 25	3	25 Cleaning mode	Cleaning mode	3	0 ... 5	25

¹ 0 = Function not active

² x = Total number of valves (FAS 20) divided by 2 + 1 (for example: FAS 20 = 280 / x = 141)



▶ Parameters must be set before commissioning by all means.

 Parameter code 3 = ####

Parameter number	Code 	Display text	Explanation	Factory setting	Setting range	See page
Parameter block FDP1 "Δp monitoring filter cleaning"						
FDP1	3	FDP1 DP Monitoring	Parameter block "Δp monitoring filter cleaning"	1	0, 1	26
FDP1 12	3	12 DP Min SwitchP.M1	DP Min. switch point (message 1) ³	0 ¹ Pa	0 ¹ ... 4600 Pa	26
FDP1 13	3	13 DP Pre SwitchP.M2	Δp pre-switching point (message 2) ³	0 ¹ Pa	0 ¹ ... 5000 Pa	26
FDP1 14	3	14 DP Max SwitchP.M3	DP Max. switch point (message 3) ³	2000 Pa	0 ¹ ... 4800 Pa	26
FDP1 15	3	15 DP Start SwitP.M4	Δp start switching point (message 4) ³	1000 Pa	100 ... 4700 Pa	26
FDP1 16	3	16 DP Hysteresis	DP hysteresis	300 Pa	100 ... 4700 Pa	26
FDP1 17	3	17 DP Signal source	Δp signal source	70	33, 34, 37, 67, 70	26
FDP1 18	3	18 Measuring range	Δp measuring range	5000 Pa	250 Pa ... 1000 hPa	26

Individual parameters

F21	–	F21 FAS Clean.Monitr	Cleaning monitoring	0	0, 1	27
FSP	–	FSP Display language	Language of the display text	0	0 ... 2	27

Parameter block FSB "Operating hours counter"

FSB	4	FSB Op. hour count	Parameter block "Operating hours counter"	1	0, 1	27
FSB 1	4	1 Serv.op.hrs.c.mode	Operating hours counter mode "Cleaning on"	1	0, 1, 3	28
FSB 2	4	2 Service message 1M	Service message 1 (set operating hours counter mode)	3000 h	0 ¹ ... 25,000 h	28
FSB 3	5	3 Service message 2N	Service message 2 (mains voltage)	8700 h	0 ¹ ... 25,000 h	28

¹ 0 = Function not active³ The codes M1 to M4 (for message 1 to message 4) are required to change the default message assignment. This requires the entry of the commissioning parameter code. Normally a change is not necessary.

-  Parameter code 3 = ####
- Parameter code 4 = known only to the manufacturer of the filter system
- Parameter code 5 = known only to the manufacturer of the filter system

5.11 Fast display of the most important current operating and parameter values

The important operating and parameter values can be displayed in the operating mode of the controller. Briefly press the Δ key several times to call up the following information in succession on the display.

The control is in service mode

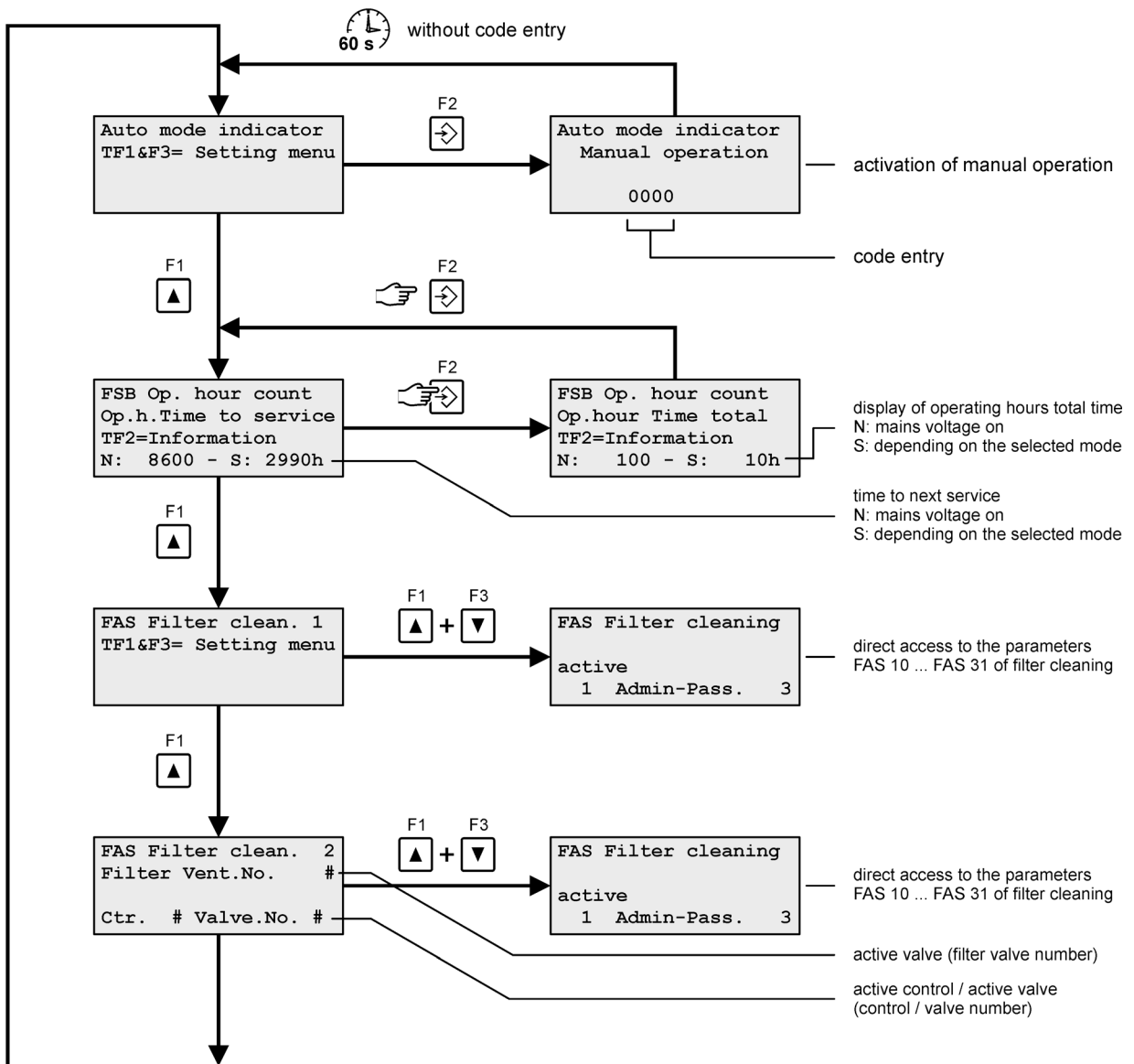

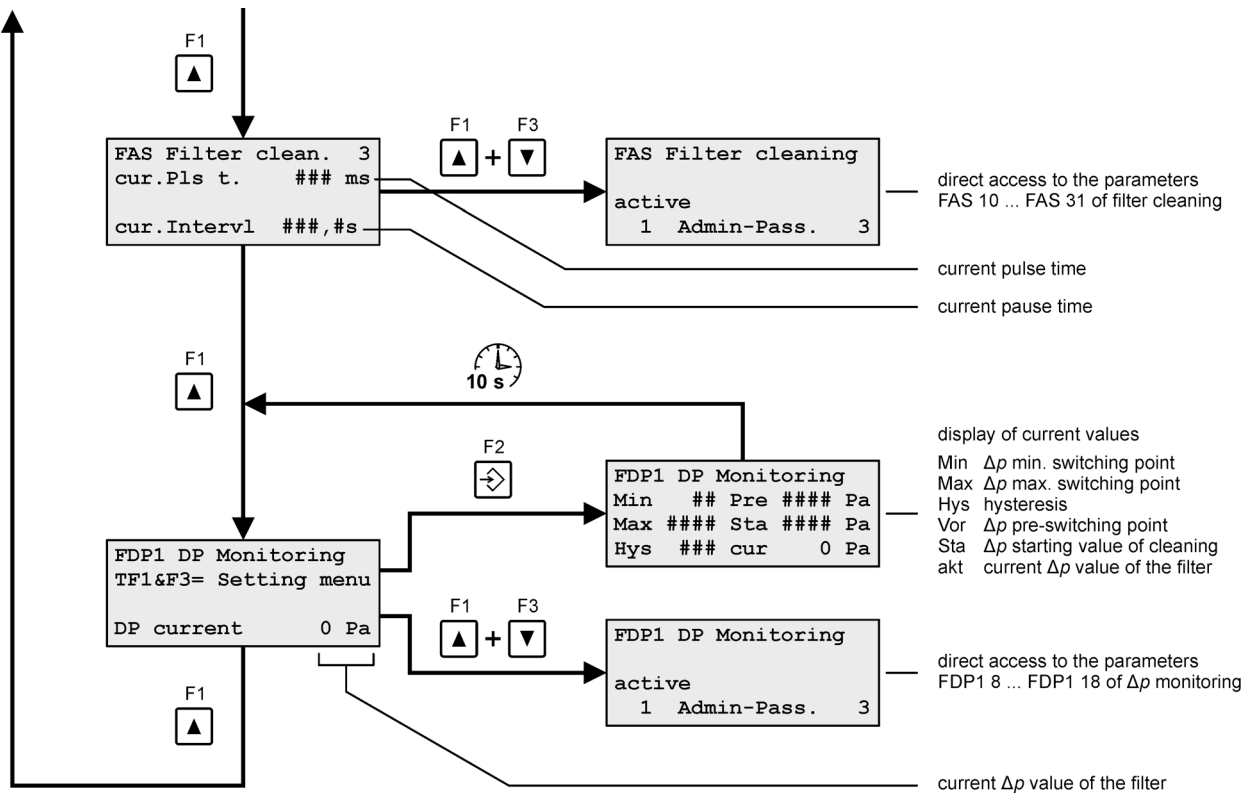

i For more information on the operating messages, see section 8.4 "Operating messages" on page 35.

5.12 Parameter description and explanation of function

Parameter block FAS "Filter cleaning"

Parameter FAS "Filter cleaning"

The parameter block "Filter cleaning" can be activated or deactivated via parameter FAS. The parameter value is factory-set to 0 (= active).

FAS =	Text in display, lines 3 and 4	Explanation
0	Not active 0	All parameters belonging to the block are not active and are hidden.
1	active 1	All parameters belonging to the block are active and are displayed.

Parameter FAS 10 "Log number"

The bus protocol of the connected I/O modules or valve boxes can be selected via parameter FAS 10. The parameter value is factory-set to 1 (=Only RM-VXX Log 1).

FAS 10 =	Text in display, lines 3 and 4	Explanation
1	Only RM-VXX Log 1 1	The cleaning control is operated with I/O modules of the type RM-V 8 or RM-V 16.
2	Only RM-VXX Log 2 2	The cleaning control is operated with I/O modules of type RM-V 8.10 or RM-V 16.10.
3	Only Autel log 3	The cleaning control is operated with valve boxes from Autel.

Parameter FAS 11 "Pause time 1"

The period between two successive cleaning pulses can be set in 0.1 second increments via parameter FAS 11.

Parameter FAS 12 "Pause time mode"

The parameter is factory-set to 0 and is therefore not active. With parameter setting FAS 12 = 1 all intervals are multiplied with factor 10, **except** with active interval controller or the option "Profibus on with protocol 1".

Parameter FAS 13 "Pause time 2"

The period between two successive cleaning pulses can be set in 0.1 second increments via parameter FAS 13 during downtime and forced cleaning.

Parameter FAS 15 "Cleaning valve pulse time"

The valve pulse time of the cleaning valves can be set in 10 millisecond increments via parameter FAS 15.

Parameter FAS 16 "Cleaning valve pulse time mode"

The parameter is factory-set to 0 and is therefore not active. With the parameter setting FAS 16 =1 the pulse time of the cleaning valves is multiplied with factor 10 **except** with the option "Profibus on with protocol 1".

Parameter FAS 18 "Forced cleaning time"

The parameter is factory-set to 0 and is therefore not active. The forced cleaning time is set via parameter FAS 18. If cleaning is in the stopped state, a complete cycle is always cleaned after the set forced cleaning time has elapsed.

Parameter FAS 19 "Downtime cycles"

The downtime cycles can be set with parameter FAS 19. Interval 2 is always active during downtime.

Parameter FAS 20 "Number of valves"

The number of cleaning valves connected to the filter system can be set with parameter FAS 20.

Parameter FAS 21 "Number of I/O modules"

The number of I/O modules (RM-V 8 or RM-V 16) connected to the filter system can be set with parameter FAS 22.



A communication alarm is triggered if the number of the I/O modules detected at the controller start differs from the settings.

Parameter FAS 22 "Cleaning skip range"

In the delivery state the valves are selected in direct succession (1, 2, 3, 4 .../ skip range = 1). Depending on the filter arrangement cleaning in a different order may be useful (for example: 1, 4, 7, 10 ... / skip range = 3). The product discharge can be regulated this way. A cleaning skip range from 1 to 120 can be set with parameter FAS 22. However, the value cannot be chosen greater than half the value of the number of valves set (parameter FAS 20) plus 1.

Parameter FAS 25 "Cleaning mode"

The operating mode of differential pressure-dependent cleaning can be set with parameter FAS 25.

FAS 25 =	Text in display, lines 3 and 4	Explanation
0	Cleaning off 0	Cleaning is disabled.
1	Cleaning on P1 1	Cleaning works continuously with pause time 1 (see parameter 11).
2	Cleaning on P2 2	Cleaning works continuously with pause time 2 (see parameter 13).
3	DP Clean.Start/Stop 3	Cleaning works in start-stop mode. If the differential pressure reaches the Δp start value set via parameter FDP1 15, cleaning is enabled until the differential pressure falls below the value FDP1 15 - FDP1 16 (Δp start value minus Δp hysteresis value). The valve number selected last is stored to enable cleaning to continue with the subsequent valve when starting again.
4	DP Clean. Stop End 4	Cleaning works in stop-end mode. If the differential pressure reaches the Δp start value set via parameter FDP1 15, cleaning is enabled until the differential pressure falls below the value FDP1 15 - FDP1 16 (Δp start value minus Δp hysteresis value) and the last valve was selected.
5	DP Cln. Stop circ. 5	Cleaning works in the start-stop mode with circulation ending. If the differential pressure reaches the Δp start value set with parameter FDP1 15, the valve number is stored and cleaning is activated until the differential pressure falls below the value FDP1 15 - FDP1 16 (Δp start value minus Δp hysteresis value) and the stored valve number is reached. (At least 1 complete circulation is always carried out.)

Parameter block FDP1 " Δp monitoring filter cleaning"**Parameter FDP1 " Δp monitoring filter cleaning"**

Parameter block " Δp monitoring filter cleaning" can be activated or deactivated via parameter FDP 1. The parameter value is factory-set to 0 (= active).

FAS =	Text in display, lines 3 and 4	Explanation
0	Not active 0	All parameters belonging to the block are not active and are hidden.
1	active 1	All parameters belonging to the block are active and are displayed.

Parameter FDP1 12 " Δp min. alarm switching point"

The Δp alarm min. value is set via parameter FDP1 12.

Parameter FDP1 13 " Δp pre-alarm switching point"

The Δp pre-alarm max. value is set via parameter FDP1 13.

Parameter FDP1 14 " Δp max. alarm switching point"

The Δp alarm max. value is set via parameter FDP1 14.

Parameter FDP1 15 " Δp start switching point"

The Δp start value of differential pressure-dependent cleaning is set via parameter FDP1 15.

Parameter FDP1 16 " Δp hysteresis"

The Δp hysteresis value of differential pressure-dependent cleaning is set via parameter FDP1 16.

Parameter FDP1 17 " Δp signal source"

The source of the differential pressure measurement is set with parameter FDP1 17.

FDP1 17 =	Text in display, lines 3 and 4	Explanation
33	No assignment 33	No assignment
34	I Input 2 34	Δp measurement via the 4-20 mA input 2 of the RM-351 C / 310 (terminal 41)
37	I Input 1 RMV 1 37	Δp measurement via the current input of the I/O module RM- 8 or RM-V 16 with the address No. 1
67	DP Sensor 1 67	Δp measurement via sensor S1 of the RM-351 C / 310
70	DP Sensor 1 RMV 1 70	Δp measurement via the sensor of the I/O module RM-V 8 or RM-V 16 with the address No. 1

Parameter FDP1 18 " Δp measuring range"

The Δp measuring range of the selected sensor (see parameter FDP1 17 " Δp signal source") is set via parameter FDP1 18. The measuring range is set to 5000 Pa at the factory. If a sensor with a different measuring range is used, the control can be adjusted via this parameter. The 4-20 mA output assigned to the sensor is considered accordingly. The measuring range is adjustable from 250 to 50,000 Pa in 250 Pa increments. The next higher and also last value is 1000 hPa.

Individual parameters

Parameter F21 "Cleaning monitoring"

The parameter is factory-set to 0 and is therefore not active. The cleaning monitoring of the filter control can be activated or deactivated via parameter 21.

FAS =	Text in display, lines 3 and 4	Explanation
0	Not active 0	All parameters belonging to the block are not active and are hidden.
1	active 1	All parameters belonging to the block are active and are displayed.

If the parameter is set to the value 1, the cleaning monitoring is switched on. The controller monitors whether a defined current flows through each controlled valve. If no current flows at a valve five times in succession, an alarm message with the valve number and control number of the valve concerned is shown in the display (see section 8.5 "Service and alarm messages" on page 41). The alarm message is saved and can be reset by pressing the F2 (ENTER) key.

Parameter FSP "National language"

The display texts can be shown in different national languages. The text output is in German when the system is delivered.

FSP =	Text in display, lines 3 and 4	Explanation
0	D - Deutsch 0	Text output German
1	GB - English 1	Text output English
2	F - Francais 2	Text output French



It is possible to replace the French-language text edition with an edition in another language. See appendix 21

Parameter block FSB "Operating hours counter"

Parameter FSB "Operating hours counter"

The parameter block "Operating hours counter" can be activated or deactivated via parameter FSB. The parameter value is factory-set to 0 (= active).

FSB =	Text in display, lines 3 and 4	Explanation
0	Not active 0	All parameters belonging to the block are not active and are hidden. However, the operating hours counter, which counts when the supply voltage is applied, continues to run.
1	active 1	All parameters belonging to the block are active and are displayed.

The control has the following four time counters:

- The **operating hours counter** "Mains on" counts up as soon as the supply voltage is applied. The counter cannot be reset. If the counter reaches the value 60,000 hours, it stops.
- The **Service operating hours counter** counts up in the mode set via parameter FSB 1. The counter cannot be reset. . If the counter reaches the value 60,000 hours, it stops.
- The **Service message counter 1** counts down from the value set via parameter FSB 3 (factory setting 3000 hours) in the mode set via parameter FSB 1. If the counter reaches the value 0, the text message "FSB Service Op.hrs" appears on the display of the RM-351 C / 310 filter control and the yellow service LED on the front lights up. You can suppress a service message that appears for a period of 24 hours by pressing the ENTER key. To reset the counter to the initial value, change to the parameter selection level, call up the window for entering the function code and enter the corresponding function code.
- The **Service message counter 2** counts down from the value set via parameter FSB 4 (factory setting = 8700 hours) as soon as the mains voltage is applied. If the counter reaches the value 0, the text message "FSB Service Op.hrs" appears on the display of the RM-351 C / 310 filter control and the yellow service LED on the front lights up. You can suppress a service message that appears for a period of 24 hours by pressing the ENTER key. To reset the counter to the initial value, change to the parameter selection level, call up the window for entering the function code and enter the corresponding function code.

Parameter FSB 1 "Operating hours counter"

The operating hours counter mode can be set via parameter FSB 1.

FSB 1 =	Text in display, lines 3 and 4	Explanation
0	Supply voltage ON 0	The counter counts when mains voltage is present.
1	Cleaning on 1	The counter counts when cleaning is activated.
3	DP > 200 Pa 3	The counter counts when the differential pressure is greater than 200 Pa.

Parameter FSB 2 "Service message 1"

Parameter FSB 2 is used to set the number of hours from which the service message counter 1 counts down. (For the function of the service message counter 1 see page 27.)

Parameter FSB 3 "Service message 2"

Parameter FSB 3 is used to set the number of hours from which the service message counter 2 counts down. (For the function of the service message counter 1 see page 27.)

6 Operating modes

6.1 Continuous cleaning (Parameter FAS 25)

Cleaning works continuously with the set pulse time (FAS 25) and the set pause time 1 (FAS 11) if parameter FAS 25 is set to value 1. In the same way it works with pause time 2 (FAS 13) if parameter FAS 25 is set to value 2.

Another option to activate continuous cleaning is the digital input assignment (see appendix 2 "Digital input assignment"). If the function "AS Ext. cl. on int.1" (value 11) is assigned to one of the digital inputs of the RM-351 C / 310 and the input is active, cleaning works continuously with the set pulse time (FAS 25) and the set pause time 1. If the function "AS Ext. cl. on int.2" (value 12) has been assigned to the digital input, cleaning works continuously with the set pulse time (FAS 25) and the set pause time 2.

The activation of continuous cleaning via the digital input has priority over the setting of parameter FAS 25. If, for example, continuous cleaning with pause time 1 was set via parameter FAS 25, but the function with pause time 2 was selected for the digital input, continuous cleaning with pause time 2 is active when the input is active.

6.2 Forced cleaning (Parameter FAS 18)

If cleaning is in the stopped state, a complete cycle with interval 2 is always cleaned after the set forced cleaning time has elapsed. Forced cleaning is deactivated when the control is in stand-by or via an external signal.

6.3 Differential pressure controlled cleaning (Parameters FDP1 15, FDP1 16, FAS 25)

Cleaning starts when the differential pressure Δp of the filter has reached the Δp start value set via parameter FDP1 15. The solenoid valves are selected. By cleaning the differential pressure drops after a certain period of time. Cleaning stops when the differential pressure reaches the value " Δp start" minus " Δp hysteresis" (Parameter FDP1 16). The following three cleaning modes can be set via parameter FAS 25.

- Start-stop operation (FAS 25 = 3)

If the differential pressure reaches the Δp start value set via parameter FDP1 15, cleaning is enabled until the differential pressure falls below the value FDP1 15 - FDP1 16 (Δp start value minus Δp hysteresis value). The valve number selected last is stored to enable cleaning to continue with the subsequent valve when starting again.

- Stop-end operation (FAS 25 = 4)

If the differential pressure reaches the Δp start value set via parameter FDP1 15, cleaning is enabled until the differential pressure falls below the value FDP1 15 - FDP1 16 (Δp start value minus Δp hysteresis value) and the last valve was selected.

- Start-stop operation with circulation termination (FAS 25 = 5)

If the differential pressure reaches the Δp start value set with parameter FDP1 15, the valve number is stored and cleaning is activated until the differential pressure falls below the value FDP1 15 - FDP1 16 (Δp start value minus Δp hysteresis value) and the stored valve number is reached. (At least 1 complete circulation is always carried out.)

6.4 Downtimecleaning

If downtime cycles were set via parameter FAS 19, downtime cleaning is active for the set number of cycles with pause time 2 (FAS 13) when the enable is removed (1 signal is present at input 1).

The following cases lead to the termination of an ongoing downtime cleaning.

- If the RM-351 C / 310 filter control unit has been parametrised in such a way that an alarm message is present which causes the system to be switched off, the downtime cleaning process is also terminated.
- If the function DEZ = 9 "AS Downtime end" (see Appendix 2 "Digital input assignment") has been assigned to a digital input of the filter control RM-351 C / 310, downtime cleaning can be terminated by an external signal at this input.

If the function DEZ = 10 "AS Downtime release" (see Appendix 2 "Digital input assignment") has been assigned to a digital input of the RM-351 C / 310 filter control unit, an external enable signal is required at this input to operate the downtime cleaning. If the signal drops out, ongoing downtime cleaning is stopped. However, it is continued with the remaining number of cycles when the enable signal is applied again.

6.5 Cleaning request and release via a control room

For filter systems that are not allowed to clean independently, a cleaning request signal is required for the control room or higher-level control system. A pending cleaning process is then blocked until the control room or higher-level control system delivers an enable signal to the RM-351 C / 310 filter control system. Only then does cleaning start.

To output the cleaning request signal, select a digital output of the RM-351 C / 310 and assign the function DAZ = 19 "AS Cleaning request" to it (see Appendix 1 "Digital output assignment"). As enable input, select a digital input of the RM-351 C / 310 and assign the function DEZ = 6 "AS Cl. on if requ." to it (see Appendix 2 "Digital Input Assignment"). If the RM-351 C / 310 filter control system is parametrised in the manner described and wired to the control room or higher-level control system, the cleaning request and release functions as described above.

6.6 Activation of cleaning via an external input signal

See section 6.1 "Continuous cleaning (Parameter FAS 25)" on page 29

6.7 Manual operation

For commissioning the filter system, the RM-351 C / 310 control unit can be switched to "Manual operation" mode. Then, the individual solenoid valves and other actuators, if any, can be switched on and off manually using the keys on the front of the device.



Before manually switching on the individual functions, the operator must be absolutely sure that the system cannot be damaged and that the personnel cannot be endangered.

To activate manual mode, the RM-351 C / 310 filter control unit must be in "Automatic mode" and the text "Auto mode indicator" for automatic mode display must appear in line 1 of the display. If this is not the case, press the Δ key briefly and repeatedly until the text mentioned appears. Cleaning must not be active. The text "No release" must be displayed in line 4 of the display. If this is not the case, apply 1 signal to input 1 to remove the enable.

Press the ENTER key to enter the code for manual operation. Enter function code 6 for manual operation as described in section 5.6 on page 14. After entering the correct code, the controller is in "manual operation" mode.

All parametrized service and alarm messages remain active. If service or alarm messages occur, their cause must first be eliminated and the message must then be acknowledged in order to operate the system manually. In manual operation all downtime functions and outputs are switched off for safety reasons.

In the valve test mode you can choose between the mode "Hd1" with automatic pulse triggering and the mode "Hd2" "FAS Filter clean.Hd2" with manual pulse triggering.

Mode "Hd1": Press the Δ button briefly and repeatedly until the text "FAS Filter clean.Hd1" appears in line 1 of the display. In text line 3, the first control address (the first I/O module or the filter control RM-351 C / 310, if connected to these cleaning valves) and the number of the currently active valve are displayed. The valves of the first I/O module or the master controller are actuated sequentially with the set control times (pulse time and pause time 1). Press the ENTER key to select the I/O module with the next higher address for the valve test.

Mode "Hd2": Press the Δ button briefly and repeatedly until the text "FAS Filter clean.Hd2" appears in line 1 of the display. In text line 3, the first control address (the first I/O module or the filter control RM-351 C / 310, if connected to these cleaning valves) and the number of the last active valve are displayed. Repeated short pressing of the I/O key will actuate the valves of the first I/O module or the master controller one after the other with the set pulse time. Press the ENTER key for a long time to select the I/O module with the next higher address for the valve test.

i If no key is pressed for 3 minutes, the RM-351 C / 310 automatically returns from manual mode to "automatic mode".

7 Functions for commissioning and service purposes

For commissioning and service purposes, the following functions can be activated by entering the function code.

Function code		Explanation
No.	Code	
8	####	Master reset code for resetting all existing messages
9	####	Commissioning code for displaying and enabling the hidden commissioning parameters
10	####	Operating hours counter mode Reset Code for resetting all counter modes of the time counters of the controller to the default settings
11	####	Operating hours counter All Reset Code for resetting all 4 time counters of the controller and the counter modes to the default settings.
12	####	Production test program (only for the manufacturer)

Function code entry

To enter a function code, you must change from the operating level to the parameter selection level as described in section 5.4. In normal case (automatic mode) the display already shows the window for entering the function code. If line 1 does not contain the text "FH Funct. Code In.", press the Δ key briefly and repeatedly until the window mentioned appears. Press the ENTER key and enter the function code of the desired function as described in section 5.6. The function is then activated.

8 Text messages on the display

8.1 Program start

Display	Explanation
<pre>RM-351C/310 Versionsnummer x !!! Booting !!! Datum: xx.xx.20xx</pre>	The name of the program, the version number and the date of the program release are displayed for approx. 2 seconds after switching on the supply voltage.
<pre>Text Version RM-351 Pr.Flag 4 STR Ver.1 xx.xx.20xx</pre>	The name of the display text file and its version number are displayed then for another 2 seconds. The device powers up during these 4 seconds and conducts a self-test.

8.2 I/O module initialisation

Display	Explanation
<pre>RM-V Initialisation</pre>	Line 1 Initialisation of the connected I/O module RM-V 8 or RM-V 16 is active.

If parameter FAS 21 (number of I/O modules) has been set to a value greater than zero and cleaning has been activated (FAS 25 > 0), I/O module initialisation will take place when the supply voltage is switched on or after one or more values of parameters FAS 10, FAS 20, FAS 21 or FAS 24 have been changed. The number of available I/O modules is compared with the set number. Also, the number of detected valves is compared with the set number of valves. If an I/O module does not respond to the bus communication for 30 seconds, a communication alarm (text message: FBS Communication) is output. If the number of valves does not match, a setting alarm (text message: FAS Valve setting) is reported.

8.3 Meaning of the signs in the differential pressure display

Display	Explanation
<div style="border: 1px solid black; padding: 2px; display: inline-block;">DP current -250 Pa</div> Line 4 Display sample -250 Pa	<p>Minus sign (-) before the actual differential pressure value. The differential pressure is negative.</p> <p>Check the following points:</p> <ul style="list-style-type: none"> ▪ Differential pressure measurement hoses swapped? ▪ Analog input connected incorrectly? ▪ Δp sensor defective?
<div style="border: 1px solid black; padding: 2px; display: inline-block;">DP current <250 Pa</div> Line 4 Display sample <250 Pa	<p>Less than sign (<) before the actual differential pressure value. The negative differential pressure is greater than -250 Pa or the analog signal is less than 3.0 mA.</p> <p>Check the following points:</p> <ul style="list-style-type: none"> ▪ Differential pressure measurement hoses swapped? ▪ Analog input connected incorrectly? ▪ Δp sensor defective? ▪ Δp sensor incorrectly plugged in or not present? ▪ 4-20 mA signal incorrectly connected?
<div style="border: 1px solid black; padding: 2px; display: inline-block;">DP current >2000 Pa</div> Line 4 Display sample >2000 Pa	<p>Greater than sign (>) before the actual differential pressure value. The actual differential pressure is greater than or equal to the set full scale value.</p> <p>Check the following points:</p> <ul style="list-style-type: none"> ▪ Δp sensor defective? ▪ 4-20 mA signal not connected? ▪ Measuring range incorrectly set? ▪ Sensor type incorrectly selected?
<div style="border: 1px solid black; padding: 2px; display: inline-block;">DP current ##### Pa</div> Line 4 Display sample	<p>4 Hash tag sign (#) before the actual differential pressure value. Via parameter FDP1 17 "no assignment" was set.</p> <p>Check the setting of parameter FDP1 17 "Δp signal source"</p>

8.4 Operating messages

In the "Automatic operation" operating mode of the filter control RM-351 C / 310 the following operating messages are either displayed directly or they can be retrieved in sequence by pressing the Δ key or the ∇ key.

Display		Erklärung
Auto mode indicator	Line 1	The control is in "Automatic operation" mode.
TF1&F3= Setting menu TF2=Manual operation TF1= + / TF3= - Menu	Line 2 Line 2 Line 2	The following 3 operating instructions change every 2 seconds → <ul style="list-style-type: none"> By pressing the F1 and F3 keys (Δ and ∇) together you can access the setting menu (parameter selection level). (only when the control is not enabled) Press the F2 key (ENTER) to activate the "manual operation" mode. Press the F1 key (Δ) to scroll through a window in the operating messages menu. Press the F3 key (∇) to scroll back one window.
DP current #### Pa	Line 3	The current Δp value of the filter from the FDP1 function is displayed.
No release	Line 4	In line 4, the current status of the RM-351 C / 310 filter control is displayed. Here: The control is not enabled.
Ext.Cleaning.off #	Line 4	Cleaning was switched off via an external input signal or via FSB bus function #.
Clean. requested	Line 4	The cleaning has been requested but not yet released externally.
Ext.Cleaning.On #	Line 4	Cleaning was switched on via an external input signal or via FSB bus function #.
Downtime interpt.###	Line 4	Downtime cleaning is active, but was interrupted by the external input signal.
Downtime active# ###	Line 4	Downtime cleaning is active. ### = Downtime cycles # = FBS function „Downtime“
Cont.Cleaning On	Line 4	Continuous cleaning is switched on.
Ext.Abreinig.ein 1	Line 4	Continuous cleaning with pause time 1 is switched on.
Ext.Abreinig.ein 2	Line 4	Continuous cleaning with pause time 2 is switched on.

Display		Erklärung
FDP not active Cont.Cleaning On	Line 4 Line 4	The following 2 text messages change every 2 seconds → <ul style="list-style-type: none"> ▪ FDP1 function (Δp filter cleaning) is not active. ▪ Continuous cleaning is switched on.
T-Cln.in #### min	Line 4	(Cleaning is switched off.) Forced cleaning starts in ## minutes.
Cleaning DP On	Line 4	Cleaning is switched on via the FDP1 function.
Cleaning DP Off	Line 4	Cleaning is switched off via the FDP1 function.
FSB Op. hour count Op.h.Time to service TF2=Information TF1= + / TF3= - Menu N: 8600 - S: 2990h	Line 1 Line 2 Line 3 Line 3 Line 4	Line 1: Parameter block FSB "Operating hours counter" Line 2: Operating hours / time until the next service of the filter Line 3: The following 2 operating instructions change every 2 seconds → <ul style="list-style-type: none"> ▪ By pressing the F2 key (ENTER) further information can be called up. ▪ Press the F1 key (Δ) to scroll through a window in the operating messages menu. Press the F3 key (∇) to scroll back one window. Line 4: Time until the next service of the filter N = Counted down from 8700 hours ($\approx 365 \times 24$ h) with supply voltage switched on. S = Counted down from the set number of hours in the set counter mode.
Display after pressing and holding the F2 key (ENTER)		
FSB Op. hour count Op.hour Time total TF2=Information TF1= + / TF3= - Menu N: 100 - S: 10h	Line 1 Line 2 Line 3 Line 3 Line 4	Line 1: Parameter block FSB "Operating hours counter" Line 2: Operating hours / total time Line 3: see above Line 4: Operating hours, counted up, cannot be reset N = Counter runs with supply voltage switched on. S = Counter runs in the set counter mode.

Display	Explanation	
<pre>FAS Filter clean. 1 TF1&F3= Setting menu TF1= + / TF3= - Menu No release Cleaning DP On</pre>	<p>Line 1 Line 2 Line 2 Line 3 Line 3 Line 4</p>	<p>Line 1: Parameter block FAS "Filter cleaning", window 1</p> <p>Line 2: The following 2 operating instructions change every 2 seconds →</p> <ul style="list-style-type: none"> ▪ By pressing the F1 and F3 keys (△ and ▽) together you can access the setting menu (parameter selection level) directly proceeding to the parameter block FVS "Filter cleaning". ▪ Press the F1 key (△) to scroll through a window in the operating messages menu. Press the F3 key (▽) to scroll back one window. <p>Line 3: System status – example here: The control is not enabled or blank line.</p> <p>Line 4: Control status – example here: Cleaning is switched on via the FDP1 DP function.</p>
<pre>FAS Filter clean. 2 Filter Vent.No. # No release Ctr. # Valve.No. #</pre>	<p>Line 1 Line 2 Line 3 Line 3 Line 4</p>	<p>Line 1: Parameter block FAS "Filter cleaning", window 2</p> <p>Line 2: Number (#) of the currently active filter valve</p> <p>Line 3: System status – example here: The control is not enabled or blank line.</p> <p>Line 4: Number (#) of the currently active I/O module (RM-V8 or RM-V16) / (number#) of the currently active valve of the I/O module</p>
<pre>FAS Filter clean. 3 cur.Pls t. ### ms No release cur.Intervl ###, #s</pre>	<p>Line 1 Line 2 Line 3 Line 3 Line 4</p>	<p>Line 1: Parameter block FAS "Filter cleaning", window 3</p> <p>Line 2: : currently set pulse time in milliseconds (###)</p> <p>Line 3: System status – example here: The control is not enabled or blank line.</p> <p>Line 4: currently set pause time in seconds (###, #)</p>

Display	Explanation
<pre>FDP1 DP Monitoring TF2=More infos TF1&F3= Setting menu TF1= + / TF3= - Menu No release DP current 0 Pa</pre>	<p>Line 1: Parameter block FDP1 "Δp monitoring"</p> <p>Line 2: The following 3 operating instructions change every 2 seconds →</p> <ul style="list-style-type: none"> ▪ By pressing the F2 key (ENTER) further information can be called up. ▪ By pressing the F1 and F3 keys (Δ and ∇) together you can access the setting menu (parameter selection level) directly proceeding to the parameter block FDP1 "Δp monitoring". ▪ Press the F1 key (Δ) to scroll through a window in the operating messages menu. Press the F3 key (∇) to scroll back one window. <p>Line 3: System status – example here: The control is not enabled or blank line.</p> <p>Line 4: current differential pressure of the filter in Pascal</p>
<p>Display after pressing the F2 key (ENTER)</p> <pre>FDP1 DP Monitoring Min ## Pre ##### Pa Max ##### Sta ##### Pa Hys ### cur 0 Pa</pre>	<p>Line 1: Parameter block FDP1 "Δp monitoring"</p> <p>Lines 2–4 Display of the following currently set differential pressure values and the current filter differential pressure value.</p> <p>Min Δp min. switching point (##)</p> <p>Max Δp max. switching point (####)</p> <p>Hys Δp hysteresis(###)</p> <p>Pre Δp pre-switching point (#### Pa)</p> <p>Sta Δp starting value of cleaning (#### Pa)</p> <p>act current Δp value of the filter (0 Pa – example)</p> <p>i If the current filter differential pressure reaches one of the values "Min", "Max", "Pre" or "Sta", the corresponding numerical value starts flashing.</p>

Further operating messages

The following messages occur with different states of the filter system.

Display		Explanation
Clean. requested	Line 4	Cleaning is requested, but the control room or higher-level control system has not yet supplied an enable signal to the RM-351 C / 310 filter control system. See section 6.5 on page 30.
Cleaning DP Off	Line 4	The differential pressure dependent controlled cleaning was switched off due to the falling differential pressure.
Cleaning DP On	Line 4	The differential pressure-dependent controlled cleaning was switched on due to the increasing differential pressure.
cur.Intervl 1 ### s	Line 2	Active pause time 1 of the cleaning valves in seconds
cur.Intervl 2 ### s	Line 2	Active pause time 2 of the cleaning valves in seconds
cur.Pls t. ### ms	Line 4	Active pulse time of the cleaning valves in milliseconds
No release	Line 4	Information on the system status: The control is not enabled.
Auto mode indicator	Line 1	The control is in "Automatic operation" mode.
Ext.Cleaning.off #	Line 4	Cleaning was switched off via an external input signal. # = "Cleaning off" via bus signal active
Ext.Cleaning.On #	Line 4	Cleaning was switched on via an external input signal. # = Continuous cleaning via bus signal active
Ext.Cleaning.On 1	Line 4	Cleaning with pause time 1 was switched on via an external input signal. See appendix 2 "Parametrizable input assignment".
Ext.Cleaning.On 2	Line 4	Cleaning with pause time 2 was switched on via an external input signal. See appendix 2 "Parametrizable input assignment".
FAS Filter clean. 1	Line 1	Cleaning control function Filter cleaning Automatic mode, display 1 (also 2 or 3)

Display		Explanation
FAS Filter clean.Hd1	Line 1	Cleaning control function Filter cleaning Manual operation, display 1 (also Hd2 or Hd3)
FDP1 DP Monitor.Hand	Line 1	Function Δp monitoring 1 Manual operation
FDP1 DP Monitoring #	Line 1	Function Δp monitoring 1 # = The control operates with the bus parameters
Filter Vent.No.###	Line 2	The cleaning valve with the filter number ### is active.
Cont.Cleaning On	Line 4	Continuous cleaning is active (see section 6.1 on page 29)
Downtime activ # 2	Line 4	Downtime cleaning is active and in the 2nd downtime cycle. If the display flashes, the downtime has not been enabled by the external input signal. # = Downtime cleaning was activated via the bus.
Downtime interpt.###	Line 4	Downtime cleaning is active, but was interrupted by the external input signal.
Ctr. ## Valve.No.###	Line 3	Number (##) of the currently active I/O module (RM-V8 or RM-V16) / (number###) of the currently active valve of the I/O module during valve test in manual mode.
Ctr. ## Valve.No.###	Line 4	Number (##) of the currently active I/O module (RM-V8 or RM-V16) / (number###) of the currently active valve of the I/O module while cleaning is running in automatic mode. If valves are controlled that are directly connected to the filter control unit, the control number is 1.
TF1&F3= Setting menu	Line 2	Operating note: By pressing the F1 and F3 keys (Δ and ∇) together you can access the setting menu (parameter selection level).
TF1= + / TF3= - Menu	Line 2	Operating note: Press the F1 key (Δ) to scroll through a window in the operating messages menu. Press the F3 key (∇) to scroll back one window.
TF2 +	Line 2	Operating note: By pressing the F2 key, you increase the I/O module address by 1 (valve test in manual mode)
TF2 + TF4 Pulse V+1	Line 2	Operating note: By pressing the F2 key, you increase the I/O module address by 1. By pressing the F4 key, you increase the valve number by 1 and trigger the pulse to control the valve (valve test in manual mode).

Display		Explanation
TF2=Information	Line 2	Operating note: By pressing the F2 key (ENTER) further information can be called up.
TF2=Autom. operation	Line 2	Operating note in manual mode: By pressing the F2 key (ENTER), the "manual operation" mode is left and the "automatic operation" is activated.
TF2=Manual operation	Line 2	Operating note: Press the F2 key (ENTER) to activate the "manual operation" mode.
T-Cln.in ## min	Line 4	Forced cleaning starts in ## minutes
Force clean. On	Line 4	The forced cleaning is active.

8.5 Service and alarm messages

Display		Explanation
F21 Mess.4 no.curr F2=General Acnowled.	Line 1 Line 2	<p>The following 2 text messages change every 2 seconds →</p> <ul style="list-style-type: none"> Line 1: F21 Message 4 No current (no valve current) Line 2: A general acknowledgment is given by pressing the F2 (ENTER) key. All displayed alarm or service messages that have not been assigned the "Individual acknowledgment" property are acknowledged together.
alternating with		
TF3 Alarm info 5s TF1&F3= Setting menu	Line 1 Line 2	<ul style="list-style-type: none"> Line 1: You can view more information about the valve current alarm for five seconds by pressing the F3 key (▽). Line 2: By pressing the F1 and F3 keys (△ and ▽) together you can access the setting menu (parameter selection level).
Display after pressing the F3 key (▽)		
TF3 Additional alarm Filter Valv.No.#### Ct.No.### Val.No###	Line 1 Line 2 Line 3 Line 4	<p>Line 1: Further alarm messages (if available) can be called up by pressing the F3 key (▽).</p> <p>Line 2: Filter valve number (####) of the defective valve.</p> <p>Line 3: Control number (###) and valve number (###) of the defective valve.</p>
Auto acknowledgement	Line 2	The displayed alarm message is automatically acknowledged when the cause of the alarm has been eliminated.
F2=Single Acnowledge	Line 2	A displayed alarm or service message can be acknowledged individually by pressing the F2 key (ENTER). If there are other messages, they will continue to be displayed.

Display		Explanation
F2=General Acnowled.	Line 2	All displayed alarm or service messages that have not been assigned the "Individual acknowledgement" property are acknowledged together by pressing the F2 key (ENTER).
FBS Communication ##	Line 1	The I/O module (RM-V 8 or RM-V 16) with the displayed address (##) does not respond (bus communication).
FAS Valve setting	Line 1	The set number of cleaning valves or the set number of I/O modules (RM-V 8 or RM-V 16) does not correspond to the number of connected valves or I/O modules.
No response	Line 4	The displayed I/O module (RM-V 8 or RM-V 16) does not respond (bus communication).
RMV Number #	Line 3	Number of I/O module (RM-V 8 or RM-V 16)
TF1=plus mes. 1/ n	Line 2	Operating note: If there are several messages, you can call up all messages one after the other up to the nth message by briefly pressing the F1 key (△) repeatedly.

8.6 Acknowledgement of service and alarm messages

Single acknowledgement

A displayed alarm or service message that has been assigned the property "Single acknowledgement" can be acknowledged individually. If there are other messages, they will continue to be displayed.

Group acknowledgement

All present alarm or service messages that have not been assigned the "Individual acknowledgement" property are acknowledged together.

General acknowledgement

To acknowledge all existing alarm and service messages in one step, regardless of the properties of the messages (group acknowledgement / individual acknowledgement), the following two options are available.

- Call up the window for entering the function code and enter the corresponding function code for general acknowledgement of all messages.
- Assign the function of general acknowledgement to a free digital input of the RM-351 C / 310 controller using the digital input assignment (DEC) If the input is subsequently activated, the general acknowledgement of all messages is executed.

Short-term hiding of alarm and service messages

In order to be able to operate the controller without disturbance, it may be useful to hide existing alarm and service messages at short notice. Briefly press the ENTER key for this purpose. The controller then switches to the operating level and all messages are suppressed for a period of 10 seconds.

9 Overview of all available functions

Abbreviated designation	Function / Parameter / Parameter block	Explanation	Appendix number
DAZ	Digital output assignment	Parametrizable, freely selectable, digital output function	1
DEZ	Digital input assignment	Parametrizable, freely selectable, digital input function	2
FSB	Operating hour counter	Operating and service hours counter	6
FSP	Language extension	Description of how the French-language text edition can be replaced by an edition in another language.	21

i The detailed descriptions of the individual functions, parameters and parameter blocks can be found in Appendices 1, 2 and 6 of these operating instructions.

10 Technical specifications

Item	Data
Supply voltage	100 ... 240 V AC / 24 V ... 30 V DC
Connected load	Max. 150 VA / max. 150 W
Signal inputs, digital	6 optocoupler inputs, 24 VDC internal High >15 V Low < 5 V
Signal inputs, analog	1 4-20 mA input, burden 250 Ω
Signal outputs, potential-free	4 relay outputs, potential-free max. 2 A, 250 V or 1 A, 30 VDC i Inductive loads must be wired with suitable interference suppressors.
Slots for Δp sensors	1 slot
Slots for optional plug-in modules to extend the range of functions	1 slot i See chapter 4 "Electrical installation" on page 5
Optional measuring sensors Δp measurement	Piezoresistive, overpressure-proof up to 120 kPa Measuring range: 0 ... 5000 Pa (Standard) additional measuring ranges on request Total error sensor: $\pm 1.5\%$ FSO Operating temperature range: -25 °C ... +85 °C Long term stability: < 0.5% FSO/a
Fuses	1 PTC fuse 1.85 A i A tripped fuse is reset after the fault has been eliminated if the supply voltage remains switched off for at least 5 seconds.
Terminals	Spring-cage terminal blocks Admissible cross section Single-wire: 22 ... 16 AWG / 0.5 ... 1.5 mm ² Stranded: 22 ... 16 AWG / 0.5 ... 1.5 mm ² Stripping length: 9 ... 10 mm  To open the tension spring-loaded terminals, use a screwdriver with a blade width of max. 3 mm. The use of larger screwdrivers may cause damage to the terminals

Item	Data
Temperature range / humidity	Operation: -20 °C to +60 °C Transport: -20 °C to +60 °C Storage: -20 °C to +60 °C 75% relative humidity, no condensation
Protection class	IP-66 (front in installed condition)
Air and creepage distances EN 61010	Contamination degree 2, overvoltage category II
Dimensions	see section 3 "Mechanical installation" on page 4
Weight without optional modules and Δp sensors	Approx. 0,8 kg
Altitude	Max. 3000 m above sea level

Disclaimer

The contents of this documentation have been verified for correctness and completeness. Nevertheless, errors cannot be excluded and we can therefore not guarantee the correctness of this information. Subject to alterations at any time.